



eLock-600M

Features

eLock-600M series electromagnetic lock is designed so that the Magnet can be morticed into door Frame.

Specification

- 600lbs holding force
- Dual voltage 12 & 24 Vdc
- Current drawn 500mA / 250mA
- MOV surge protection
- Fail-Safe type
- Unmonitored model
- Push-off button on armature for instant release
- CE approved
- Dimension : -
 - Magnet : 232(L) X 38(W) X 27(D) mm
 - Armature Plate : 170(L) X 38(W) X 11(D) mm

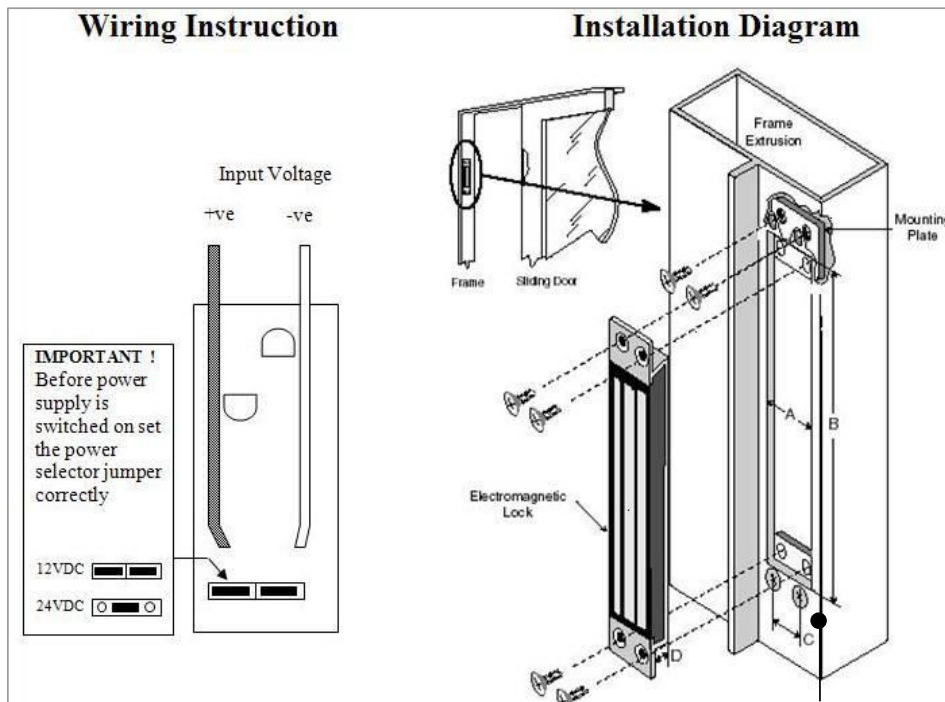

ORDERING INFORMATION

101-168 600LB MORTISE MAG LOCK